

Schematic:

REV.	ECN NO.	DESCRIPTION	DATE	APPD
A	REL		2010/03/25	

PCB SIDE TO PHY

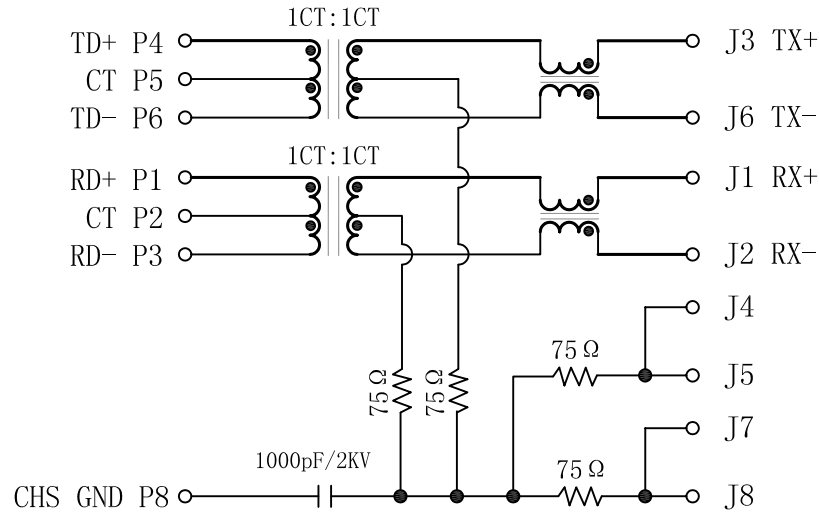

CABLE SIDE

Electrical Specifications @25°C

- Turns Ratio ($\pm 3\%$):
TX=1CT:1CT RX=1CT:1CT
- Inductance: 350uH MIN
@100KHz, 0.1V, 8mA DC BIAS
- Insertion Loss:
1-65MHz: -1.0dB MAX
- Return Loss ($100 \Omega \pm 15 \Omega$):
1-10MHz: -20dB MIN
10-30MHz: -16dB MIN
30-60MHz: -12dB MIN
60-80MHz: -12dB MIN
- Crosstalk:
1-30MHz: -40dB MIN
30-60MHz: -35dB MIN
60-100MHz: -30dB MIN
- Common Mode Rejection:
1-50MHz: -30dB MIN
50-150MHz: -20dB MIN
- Hipot: 1500Vrms
- Operating Temperature: 0°C ~ 70°C.



X:X	± 0.20	APPD:	LINK-PP INT'L TECHNOLOGY CO., LIMITED	
X:XX	± 0.10	CHKD:	TITLE: RJ45 10/100 Base-T Transformer 2×1	
X:XXX	± 0.05	DR: TOM	PART NO. : LPJ17202CNL	
ANGLES	$\pm 1^\circ$	UNIT: mm	DWG NO. : LP10032506	
	SCALE: 2/1	SHEET: 1/2	REV: A	

Mechanical:

REV.	ECN NO.	DESCRIPTION	DATE	APPD
A	REL		2010/03/25	

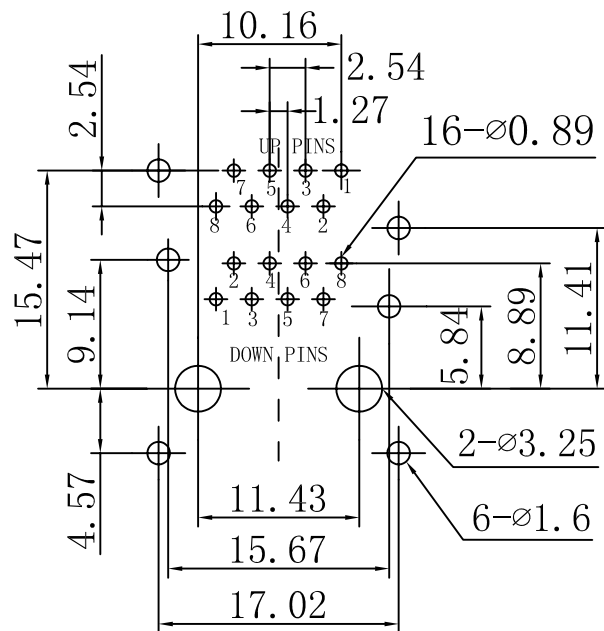
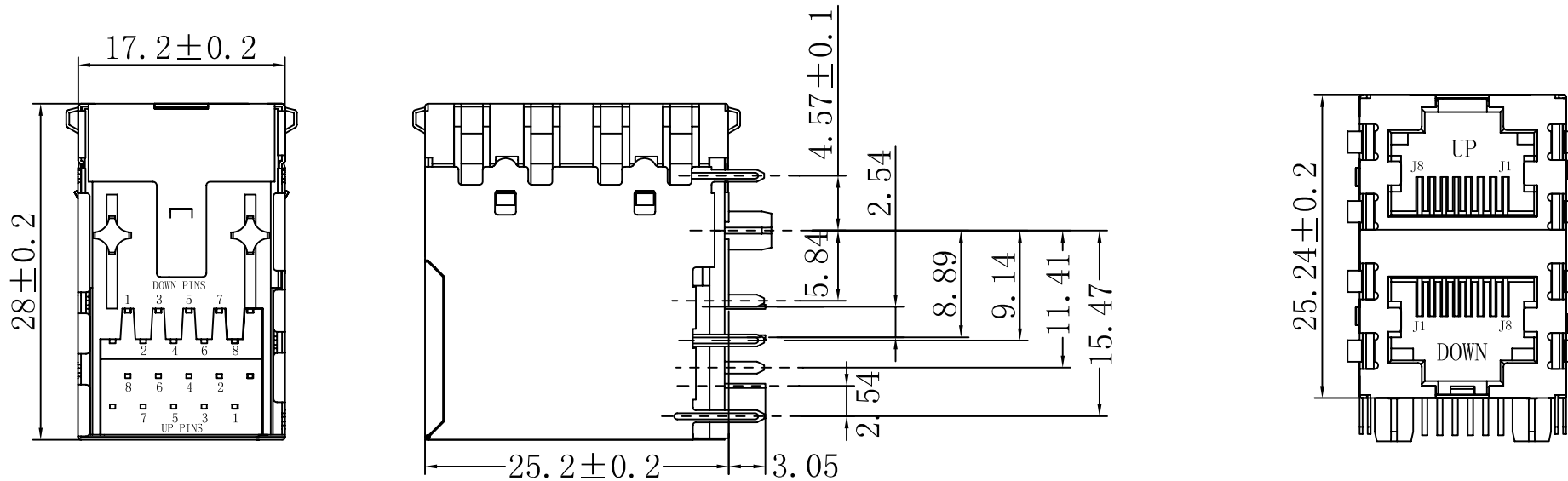

SUGGESTED PCB LAYOUT (TOP VIEW)

NOTES:

1. Designed to support application, such as SOHO (ADSL modems), LAN-on-Motherboard (LOM), hub and Switches.
2. Meets IEEE 802.3 specification
3. Connector Materials:
 Housing: Thermoplastic UL94V-0
 Contact/Shield: Copper alloy
 Shield plating: Nickel
 Contact plating: Gold 6 micro-inches min. In contact area.
4. Wave solder tip temperature: 265°C Max
 Wave solder tip temperature time: 5 Sec Max



X:X	±0.20	APPD:	LINK-PP INT'L TECHNOLOGY CO., LIMITED
X:XX	±0.10	CHKD:	
X:XXX	±0.05	DR: TOM	TITLE: RJ45 10/100 Base-T Transformer 2×1
ANGLES	±1°	UNIT: mm	PART NO.: LPJ17202CNL
	SCALE: 2/1	SHEET: 2/2	REV: A DWG NO.: LP10032506