

Schematic:

REV.	ECN NO.	DESCRIPTION	DATE	APPD
A	REL		2010/09/14	

PC BOARD CONNECTIONS

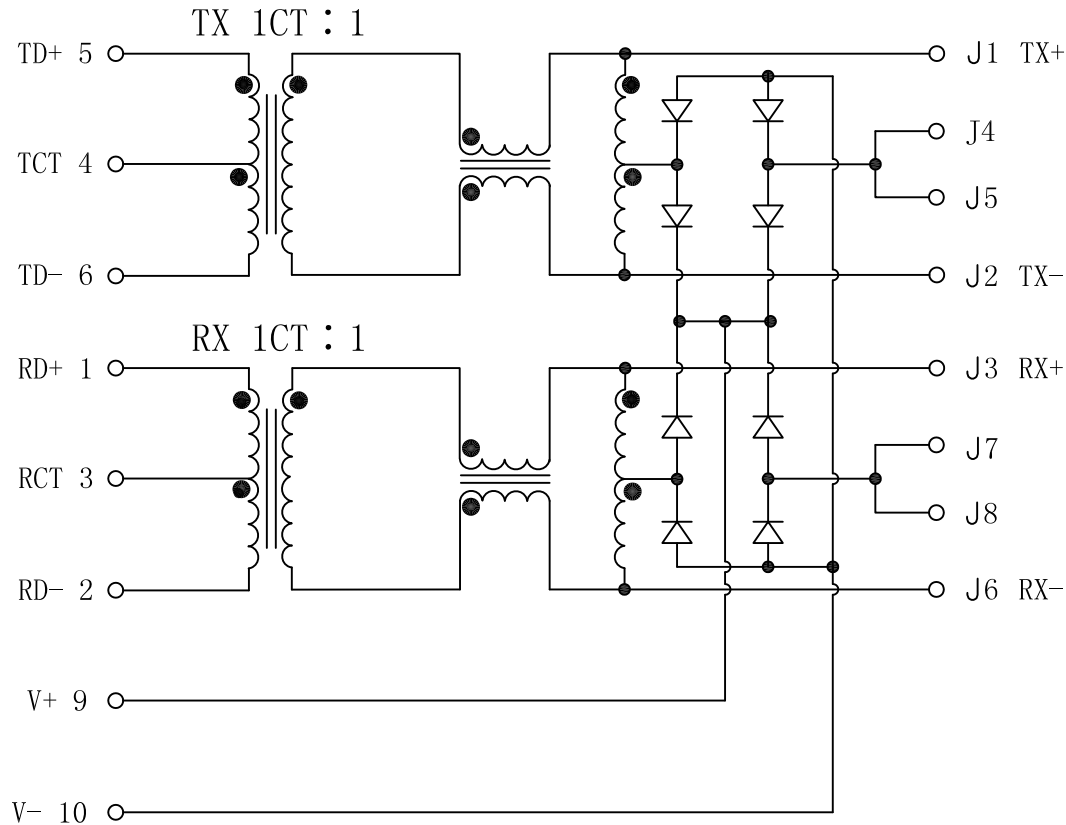

RJ45 CONNECTIONS

ELECTRICAL SPECIFICATIONS @25°C

- Turn Ratio ($\pm 2\%$):
TX=1CT : 1 RX=1CT : 1
- Inductance OCL: 350uH MIN
@100KHz/0.1V, 8mA DC Bias
- Insertion Loss:
-1.0dB MAX @ 1.0-100MHz
- Return Loss:
-18dB MIN @ 1-10MHz
-16dB MIN @ 10-30MHz
-12dB MIN @ 30-60MHz
-10dB MIN @ 60-100MHz
- Cross talk:
-40dB MIN @ 1-30MHz
-35dB MIN @ 30-60MHz
-30dB MIN @ 60-100MHz
- Common Mode Rejection:
-30dB MIN @ 1-50MHz
-20dB MIN @ 50-150MHz
- Hipot Test: 1500Vrms MIN
- Operating Temperature Range: 0°C TO 70°C

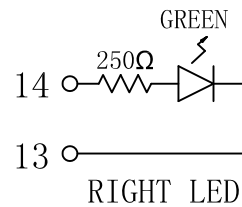
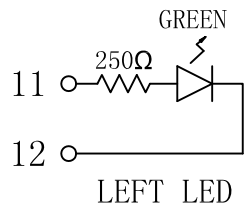

Emitting Color	λ_p (nm)	VF@IF=20mA	IR @VR=5V
Green	570	1.8~2.6V	10 μ A max

X:X	± 0.30	APPD:	LINK-PP INT'L TECHNOLOGY CO., LIMITED	
X:XX	± 0.25	CHKD:		
X:XXX	± 0.05	DR: TOM	TITLE: RJ45 Connector with 10/100 Base-T Integrated Magnetics For PoE Application	
ANGLES	$\pm 1^\circ$	UNIT: mm	PART NO. : LPJ0049A76NL	
	SCALE: 2/1	SHEET: 1/2	REV: A	DWG NO. : LP10091403

Mechanical:

REV.	ECN NO.	DESCRIPTION	DATE	APPD
A	REL		2010/09/14	

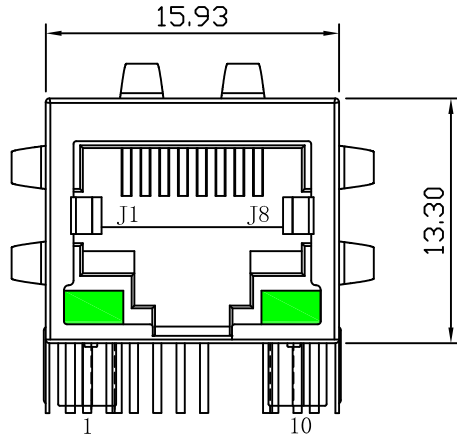

Front Side View

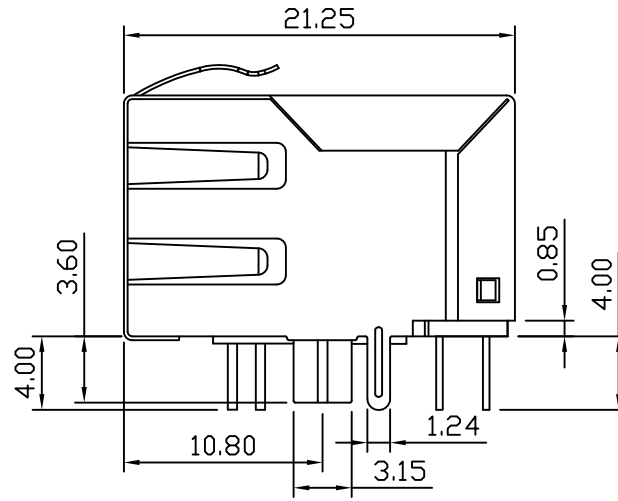

Left Side View

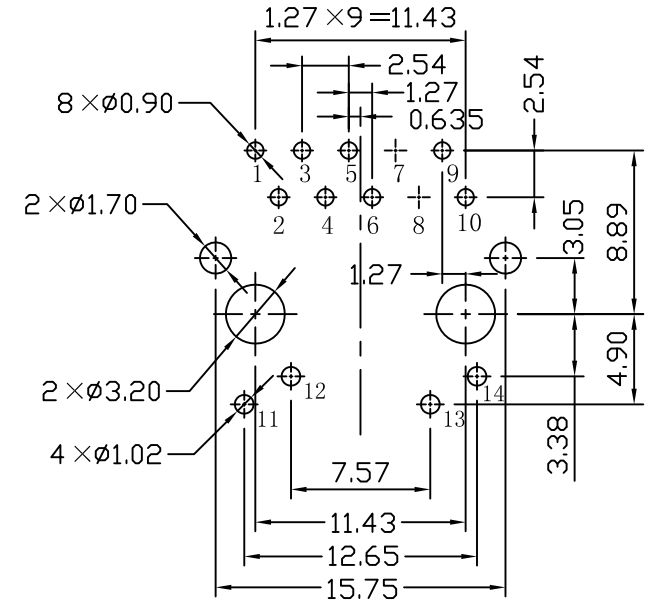

Suggested PCB Layout (Top View)

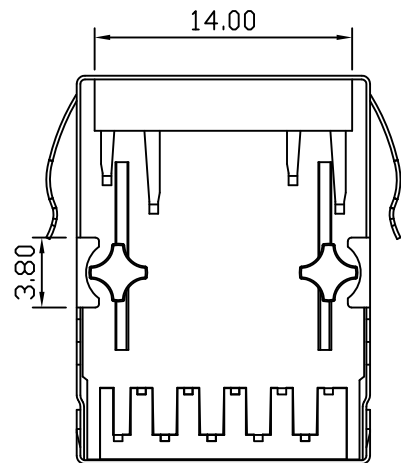

Bottom Side View

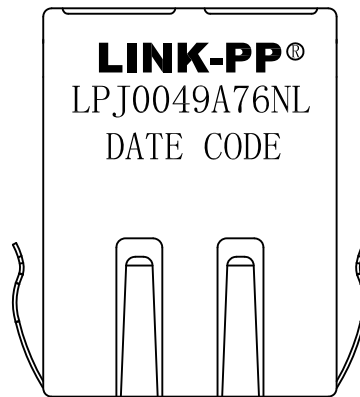

Top Side View

NOTES:

1. Designed to support application, such as SOHO (ADSL modems), LAN-on-Motherboard (LOM), hub and Switches.
2. Meets IEEE 802.3af specification
3. Designed to handle 350mA DC for PoE
4. Connector Materials:
 Housing: Thermoplastic PBT+30%G. F UL94V-0
 Contact: Phosphor Bronze C5210R-EH Thickness=0.35mm
 Pins: Brass C2680R-H Thickness=0.35mm
 Shield: SUS 201-1/2H Thickness=0.2mm
 Contact plating: Gold 6 micro-inches Min. In contact area.
5. Wave solder tip temperature: 265°C Max, 5 Sec Max.

X:X	±0.30	APPD:	LINK-PP INT'L TECHNOLOGY CO., LIMITED	
X:XX	±0.25	CHKD:		
X:XXX	±0.05	DR: TOM	TITLE: RJ45 Connector with 10/100 Base-T Integrated Magnetics For PoE Application	
ANGLES	±1°	UNIT: mm	PART NO.: LPJ0049A76NL	
	SCALE: 2/1	SHEET: 2/2	REV: A	DWG NO.: LP10091403