

# Schematic:

REV.	ECN NO.	DESCRIPTION	DATE	APPD
A	REL		2016-04-02	

## CHIP SIDE

## LINE SIDE

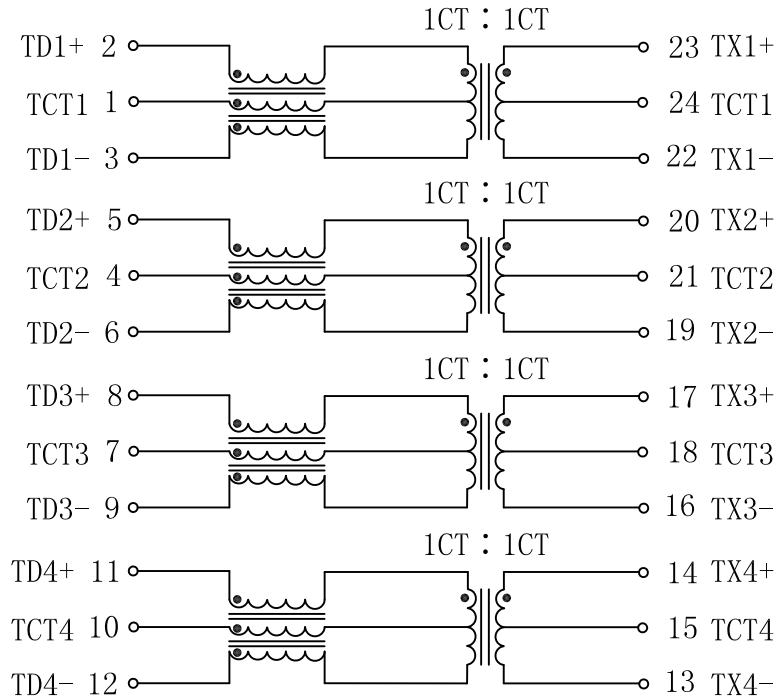

## ELECTRICAL SPECIFICATIONS @25°C

- Turn Ratio ( $\pm 3\%$ ):  
Pri : Sec = 1CT : 1CT
- Inductance OCL:  
120uH MIN @100KHz 0.1V 28mA DC Bias
- DC Resistance: 0.30  $\Omega$  TYP.
- Insertion Loss:  
-1.2dB MAX @100MHz  
-0.2-0.002\*f<sup>1.4</sup> dB MAX @1~125 MHz
- Return Loss:  
-16dB MIN @1~40MHz  
-10+20\*LOG<sub>10</sub>(f/80 MHz) dB MIN @40~100 MHz
- Cross talk:  
-50dB MIN @ 1MHz  
-55+22\*LOG<sub>10</sub>(f/10) dB MIN @10~100 MHz
- Common Mode Rejection:  
-50dB MIN @2MHz  
-15+20\*LOG<sub>10</sub>(f/200) dB MIN @30~200 MHz
- DC Current/Voltage Rating:  
1200mA @57V (Continuous)
- Hipot Test: 1500Vrms
- Operating Temperature Range: -40°C ~ +85°C.



X:X	APPD:	LINK-PP INT'L TECHNOLOGY CO., LIMITED		
X:XX ±0.25	CHKD:	TITLE: 1000Base-T Single Port Transformer Modules For PoE++ Application		
X:XXX	DR: TOM	PART NO.: LP82477ANL		
ANGLES ±1°	UNIT: mm			
	SCALE: 2/1	SHEET: 1/2	REV: A	DWG NO.: LP16040219

# Mechanical :

REV.	ECN NO.	DESCRIPTION	DATE	APPD
A	REL		2016-04-02	

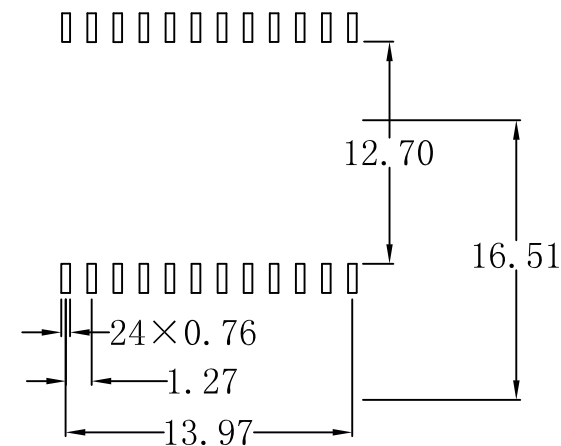
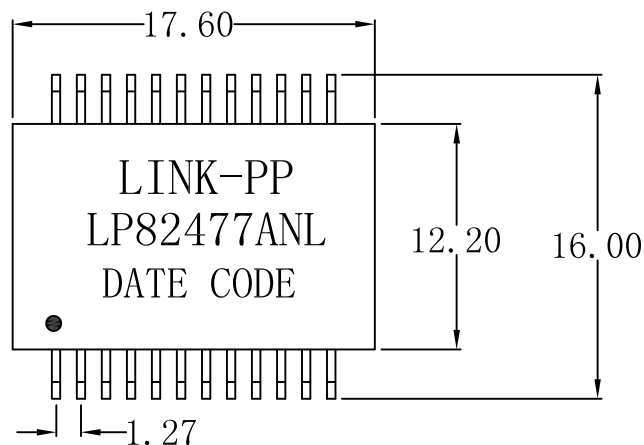

SUGGESTED PAD LAYOUT

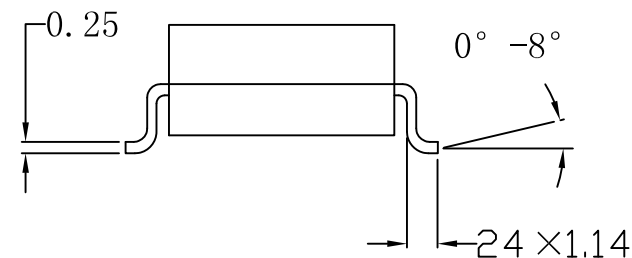
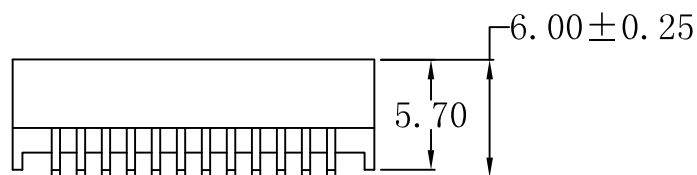

## NOTES:

1. Designed to support application, such as SOHO (ADSL modems), LAN-on-Motherboard (LOM), hub and Switches.
2. Meets IEEE 802.3bt specification.
3. Maximum reflow temperature is 250°C, 5 Sec.
4. UL certification: file number E484635.

X:X	APPD:	LINK-PP INT'L TECHNOLOGY CO., LIMITED		
X:XX ±0.25	CHKD:	TITLE: 1000Base-T Single Port Transformer Modules For PoE++ Application		
X:XXX	DR: TOM	PART NO.: LP82477ANL		
ANGLES ±1°	UNIT: mm			
	SCALE: 2/1	SHEET: 2/2	REV: A	DWG NO.: LP16040219