

REV	DESCRIPTION OF CHANGE	REVIEWED BY	ISSUE DATE
A	FIRST ISSUE	LEO	2021-10-11

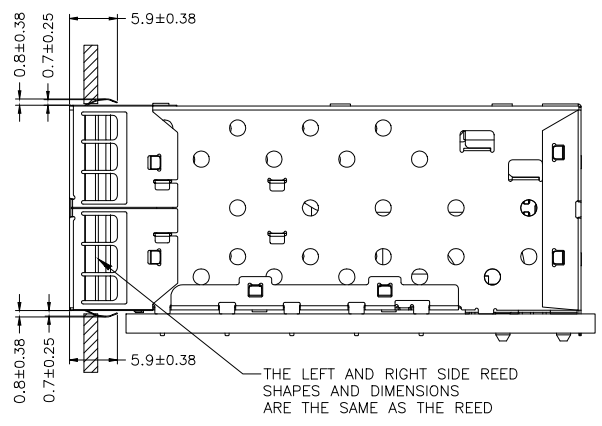

NOTES:
MATERIAL:
CAGE: COPPER ALLOY 30u" MIN NI-PLATED, THICKNESS 0.25 MM
CONNECTOR:
PLASTIC HOUSING: HIGH TEMPERATURE LCP, UL94 V-0.
LIGHT PIPE: POLYCARBONATE; COLOR: CLEAR
SPRING: STAINLESS STEEL
CONTACTS: PHOSPHOR BRONZE
CONTACT PLATING: 15u" MIN. GOLD ON MATING AREA,
150u" MATTE TIN ON SOLDER TAILS
PACKAGING: TRAY PACKAGING.
OPERATING TEMPERATURE: -40°C TO +85°C
STORAGE TEMPERATURE: -55°C TO +105°C

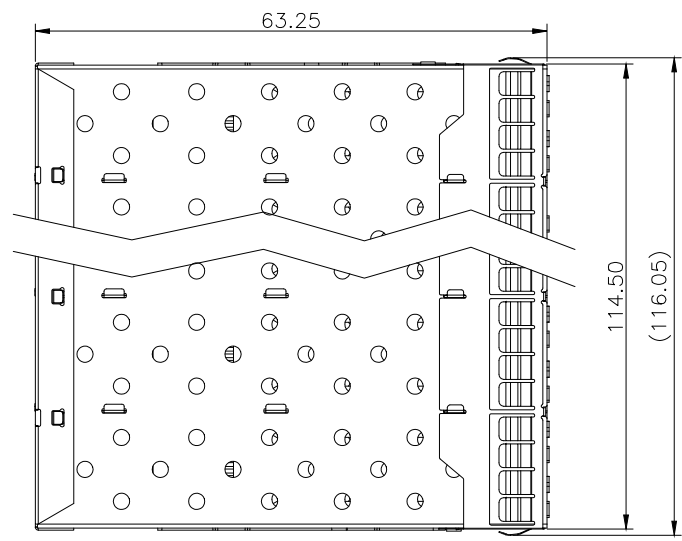
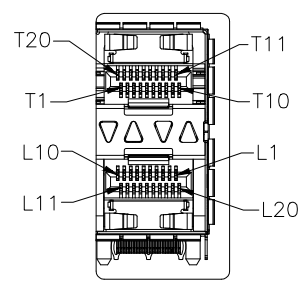
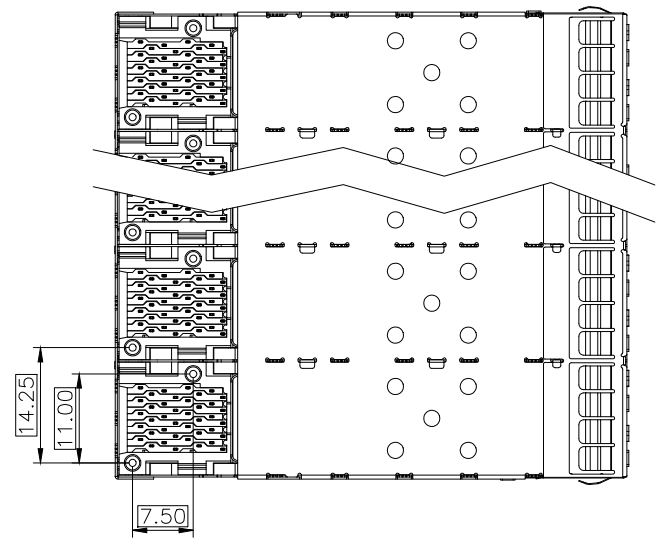
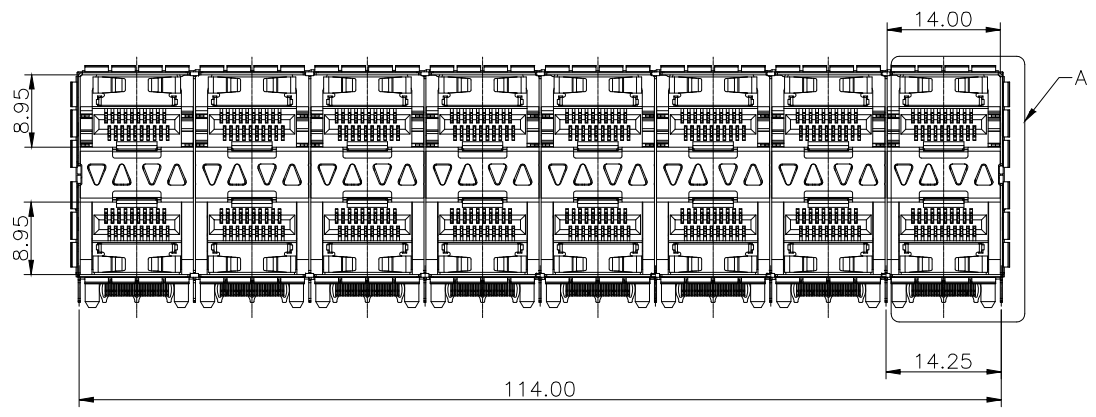
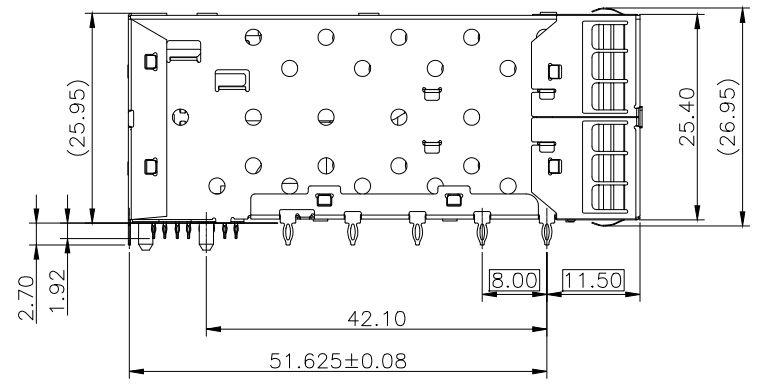

DETAIL A
1:1

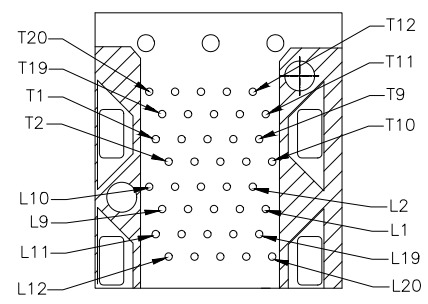

CONNECTOR PIN-OUT
COMPONENT SIDE OF BOARD



TITLE SFP+ 2X8 CAGE & CONNECTOR WITH EMI SPRING FINGER LIGHT PIPE			LINK-PP INT'L TECHNOLOGY CO., LIMITED		
PART NO. LP28BC01101			GENNERAL TOLERANCE		UNIT:MM
APPROVE	CHECK	DRAW	° X±0.20	° X±1°	SIZE:A4
LEO	JAMES	JAMES	° XX±0.15	° XX±5°	SCALE:1:1
			° XXX±0.10		SHEET:1/4
					REV:A

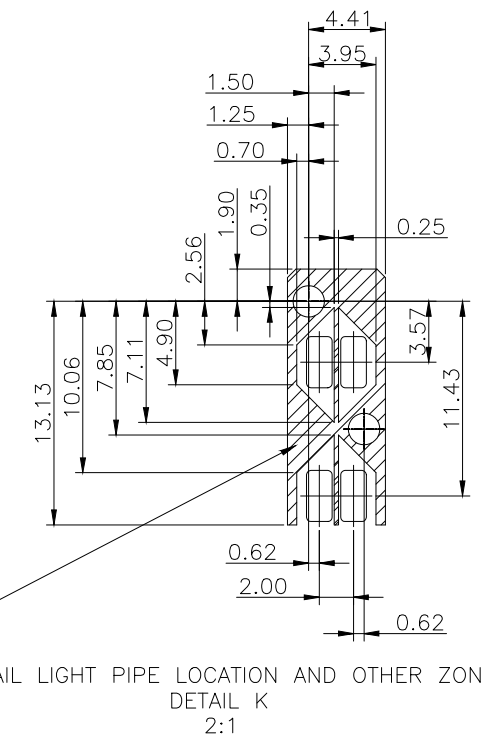
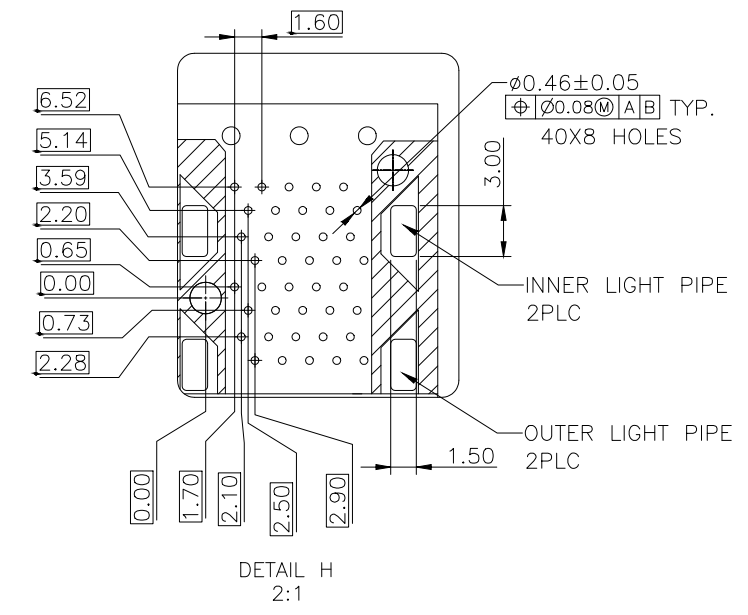
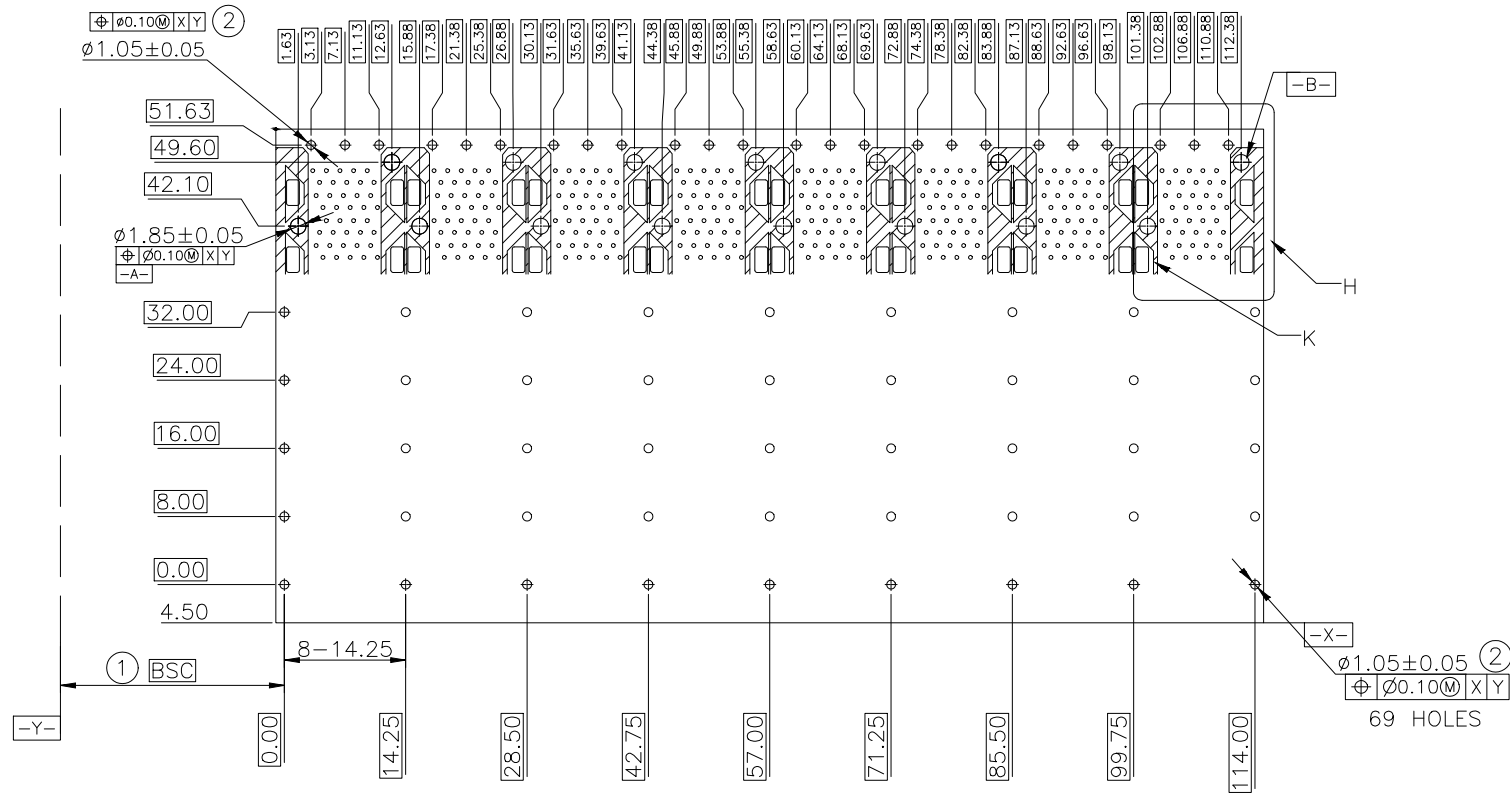

THE ENTIRE AREA OF THE CONNECTOR FOOTPRINT TO BE CONSIDERED THE KEEP OUT AREA FOR COMPONENTS (OTHER THAN LIGHT PIPE LED'S) THIS AREA IS INDICATED BY THE DASHED LINE

NOTES:

- ① DATUM AND BASIC DIMENSIONS ESTABLISHED BY CUSTOMER.
- ② 1.05 mm DIAMETER HOLES ARE CHASSIS GROUND.



TITLE SFP+ 2X8 CAGE & CONNECTOR WITH EMI SPRING FINGER LIGHT PIPE			LINK-PP INT'L TECHNOLOGY CO., LIMITED		
PART NO. LP28BC01101			GENNERAL TOLERANCE	UNIT:MM	SIZE:A4
APPROVE	CHECK	DRAW	 SCALE:1:1	SHEET:2/4	REV:A
LEO	JAMES	JAMES			

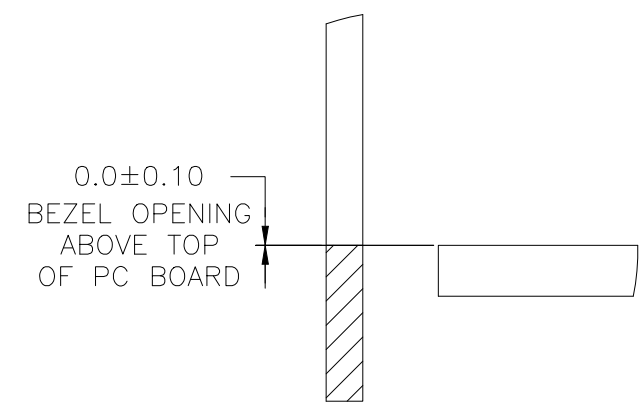
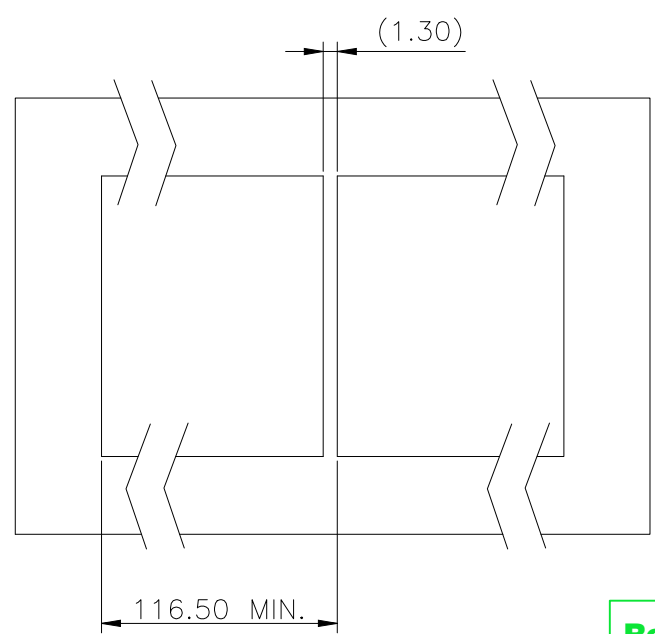
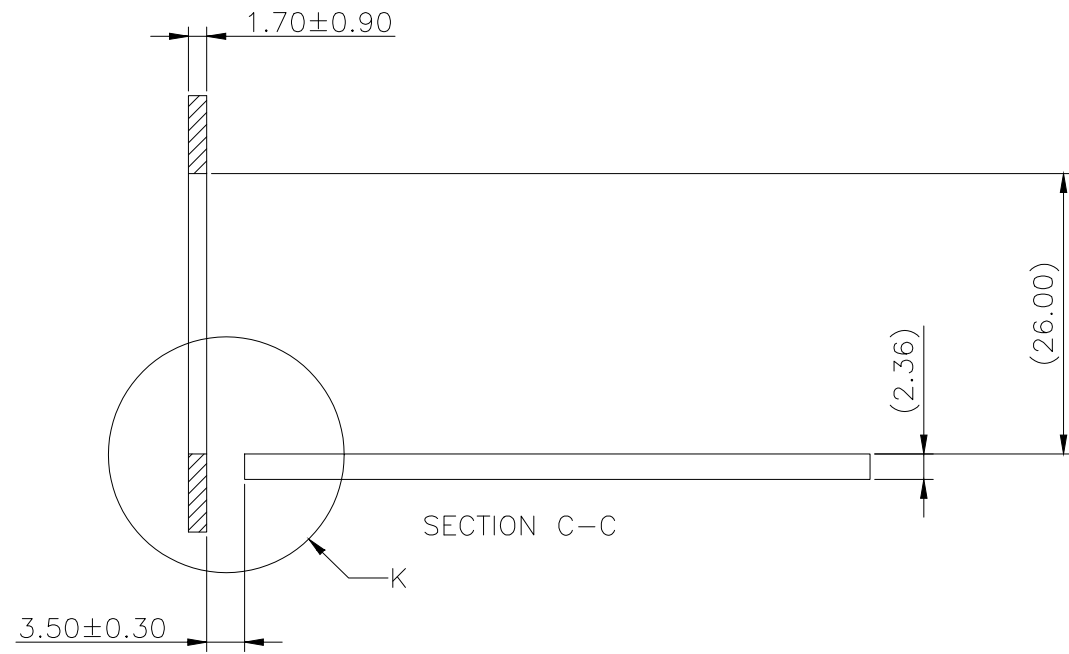
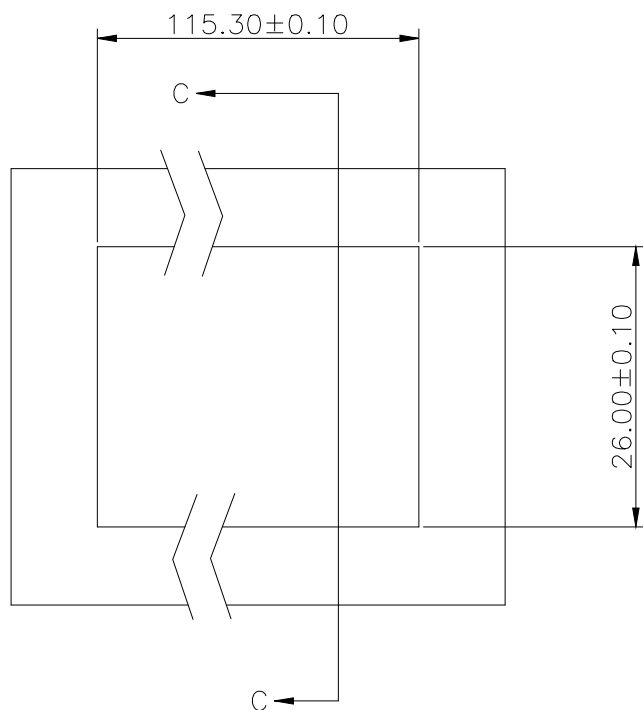

RECOMMENDED BEZEL DESIGN

DETAIL K
2:1



TITLE			SFP+ 2X8 CAGE & CONNECTOR WITH EMI SPRING FINGER LIGHT PIPE		LINK-PP INT'L TECHNOLOGY CO., LIMITED			
PART NO.			LP28BC01101		GENNERAL TOLERANCE		UNIT:MM	SIZE:A4
APPROVE	CHECK	DRAW	° X±0.20	° X±1°	SCALE:1:1	SHEET:3/4	REV:A	
LEO	JAMES	JAMES	° XX±0.15	° XX±5°				
			° XXX±0.10					

PACKAGE INFORMATION AND LABEL

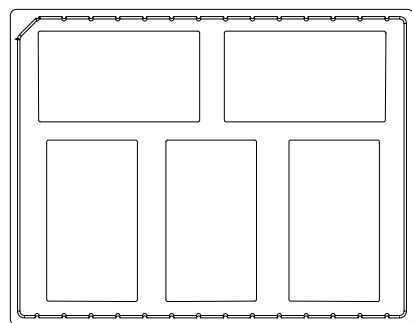

1. 5PCS PRODUCTS IN TRAYS

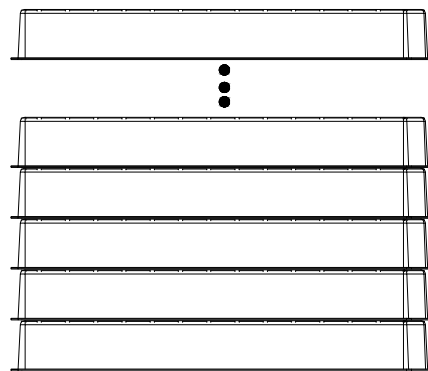

2. 4PCS TRAYS OVERLAY:
(THE NEXT TRAY NEED ROTATE 180 DEGREE AND PUT IT ON PREVIOUS TRAY.)

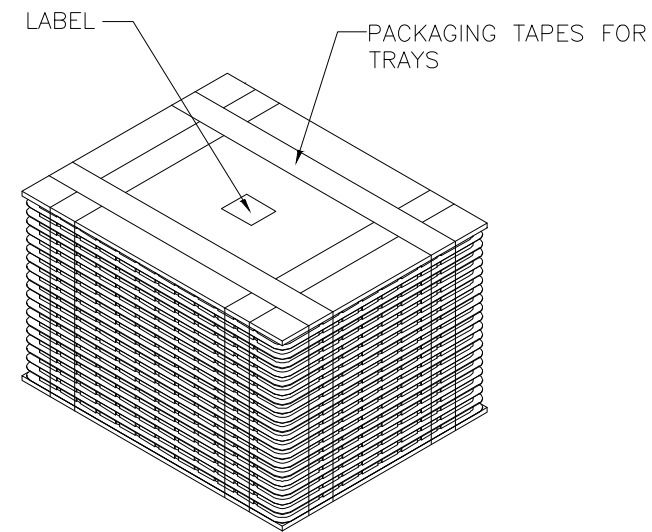

3. LABEL & PACKAGING TAPES FOR TRAYS:

PACKAGING LISTS	
ITEM	Q'TY
PRODUCT	20 PCS
TRAY	4 PCS
BOX(L340*W265*H200MM)	1 PCS
LABLE	2 PCS
PACKAGING TAPES	8 M (ABOUT)

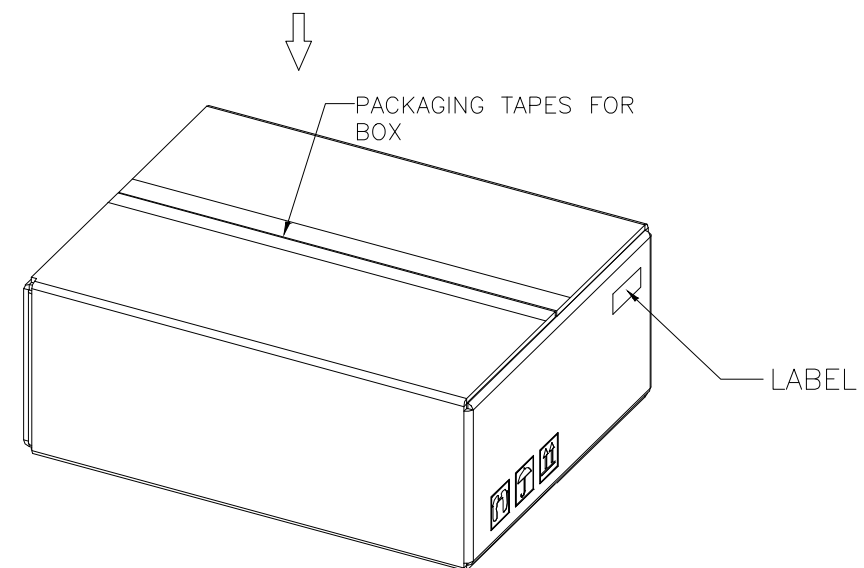

4. LABEL & PACKAGING TAPES FOR BOX



TITLE SFP+ 2X8 CAGE & CONNECTOR WITH EMI SPRING FINGER LIGHT PIPE			LINK-PP INT'L TECHNOLOGY CO., LIMITED			
PART NO. LP28BC01101			GENNERAL TOLERANCE		UNIT:MM	SIZE:A4
APPROVE	CHECK	DRAW	◦ X±0.20	◦ X±1°	SCALE:1:1	SHEET:4/4
LEO	JAMES	JAMES	◦ XX±0.15	◦ XX±5°		
			◦ XXX±0.10			
						REV:A