

REV	DESCRIPTION OF CHANGE	REVIEWED BY	ISSUE DATE
A	FIRST ISSUE	James	2021-08-01

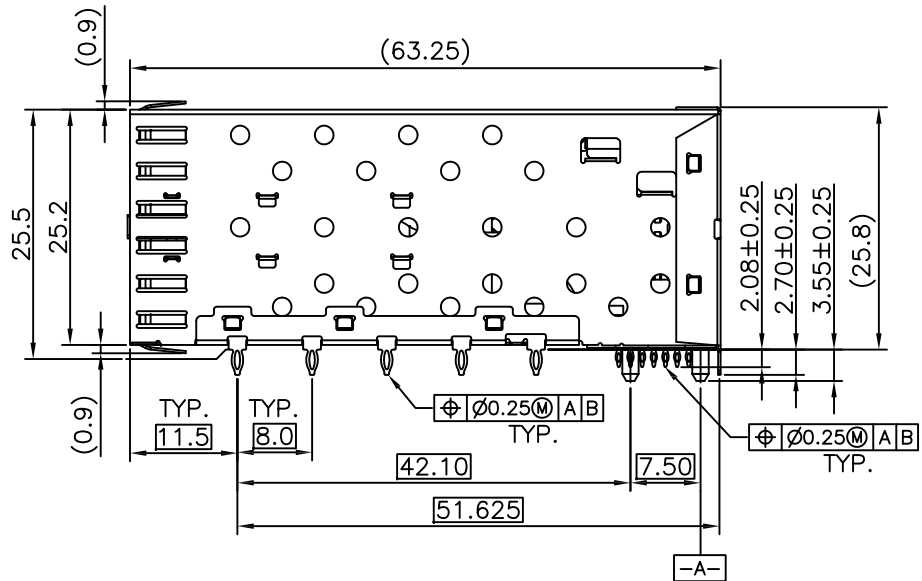

NOTES:

- MATERIAL:
- CAGE: COPPER ALLOY 30u" MIN NI-PLATED, THICKNESS 0.25 MM
- CONNECTOR:
- PLASTIC HOUSING: HIGH TEMPERATURE LCP, UL94 V-0.
- LIGHT PIPE: POLYCARBONATE; COLOR: CLEAR
- SPRING: STAINLESS STEEL, THICKNESS 0.20mm
- CONTACTS: PHOSPHOR BRONZE, THICKNESS 0.20mm
- PLATING: 15u" MIN. GOLD ON MATING AREA, 150u" MIN. MATE TIN ON SOLDER TAILS.
- PACKAGING: TRAY PACKAGING.
- OPERATING TEMPERATURE: -40°C TO +85°C
- STORAGE TEMPERATURE: -55°C TO +105°C

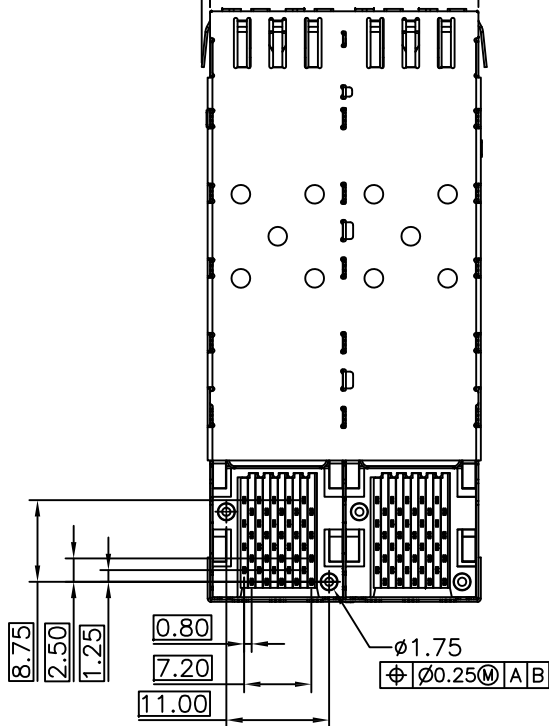
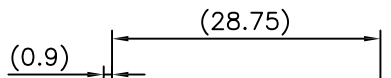
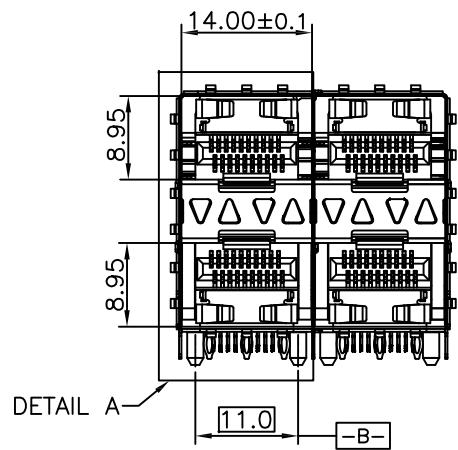

TITLE			LINK-PP INT'L TECHNOLOGY CO., LIMITED				
SFP 2X2 CAGE+CONNECTOR							
PART NO. LP22AC01101			GENERAL TOLERANCE			UNIT:MM	SIZE: A4
APPROVE	CHECK	DRAW	.X±0.20	.X±1'	SCALE: 1:1	SHEET:1/4	REV:A
James	Kevin	Kevin	.XX±0.15	.XX±5'			
			.XXX±0.10				

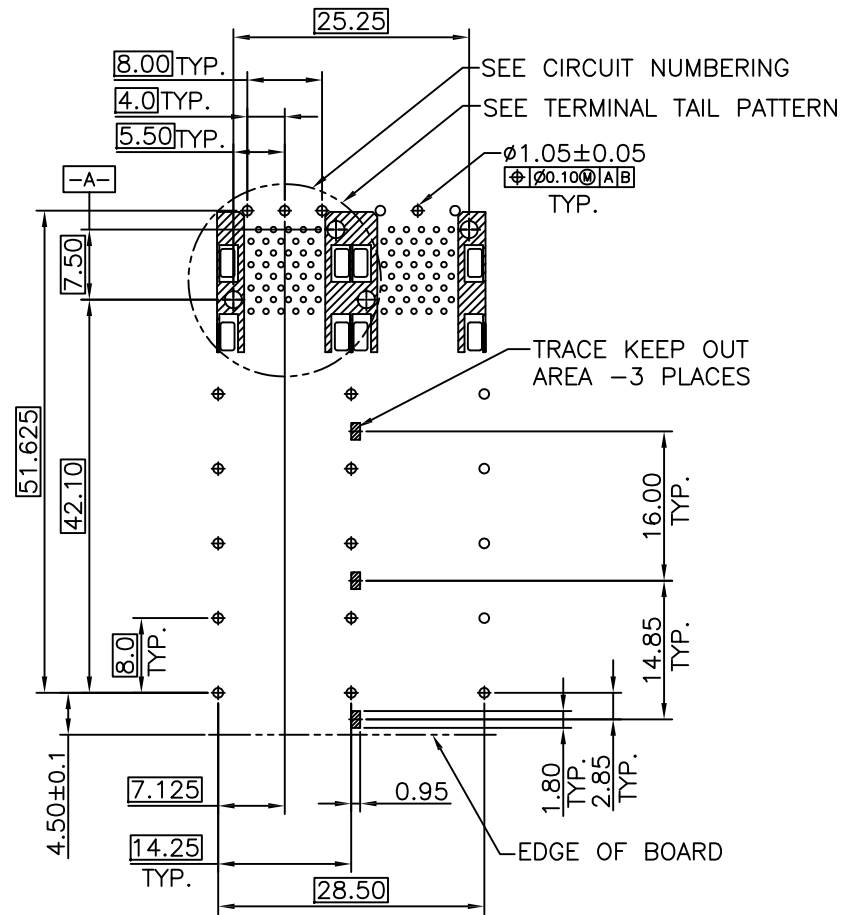
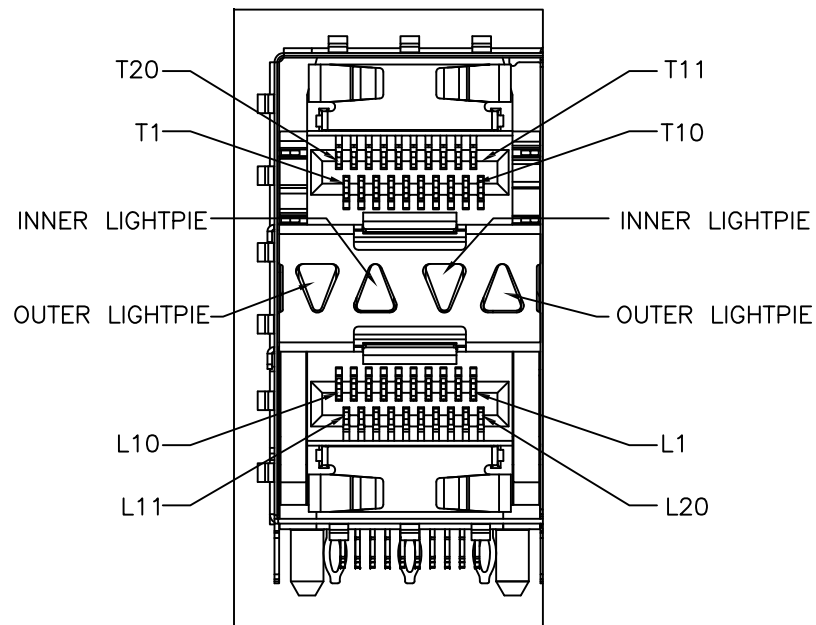
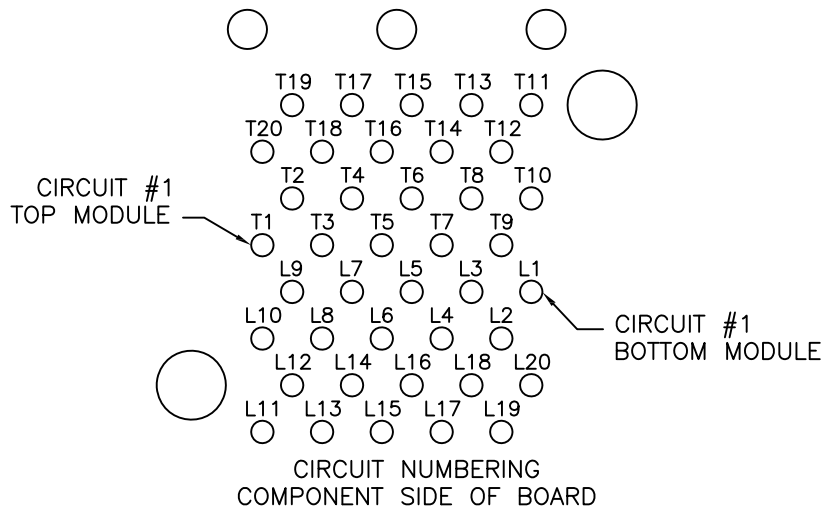

RECOMMENDED PCB LAYOUT - COMPONENT SIDE
 RECOMMENDED PCB THICKNESS : 2.36MM(.093 INCH)
 (MINIMUM PCB THICKNESS : 1.57)

THE ENTIRE AREA OF THE CONNECTOR FOOTPRINT
 TO BE CONSIDERED THE KEEP OUT AREA FOR COMPONENTS
 THIS AREA IS INDICATED BY THE DASHED LINE



TITLE		SFP 2X2 CAGE+CONNECTOR		
PART NO.		LP22AC01101	GENERAL TOLERANCE	UNIT:MM
APPROVE	CHECK	DRAW	SCALE: 1:1	SHEET:2/4
James	Kevin	Kevin		
		.X±0.20	.X±1'	REV:A
		.XX±0.15	.XX±5'	
		.XXX±0.10		

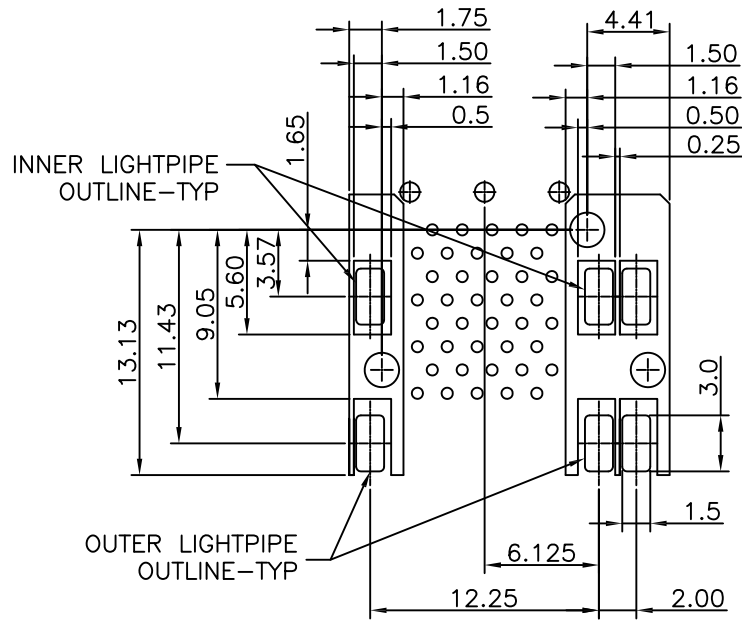

DETAIL-KEEPOUT ZONES

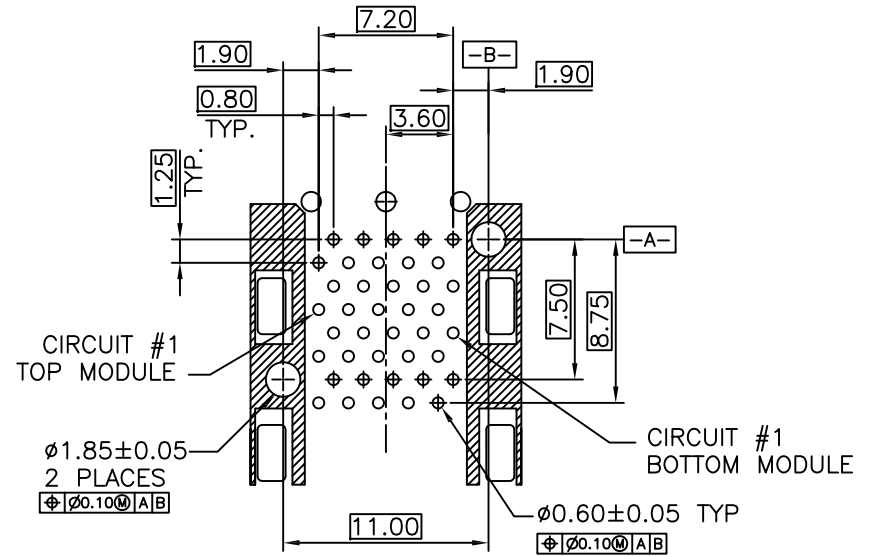

TERMINAL TAIL PATTERN

THE HATCHED AREA IN THIS VIEW INDICATES ZONES THAT ARE OCCUPIED BY THE PLASTIC HOUSING THAT SEATS AGAINST THE PCB AND BY THE VERTICAL METAL CAGE WALL THAT STOPS JUST SHORT OF THE PCB



TITLE					SFP 2X2 CAGE+CONNECTOR				
PART NO.			LP22AC01101		GENERAL TOLERANCE			UNIT:MM	SIZE: A4
APPROVE	CHECK	DRAW	.X±0.20	.X±1'	SCALE: 1:1		SHEET:3/4	REV:A	
James	Kevin	Kevin	.XX±0.15	.XX±5'					
			.XXX±0.10						

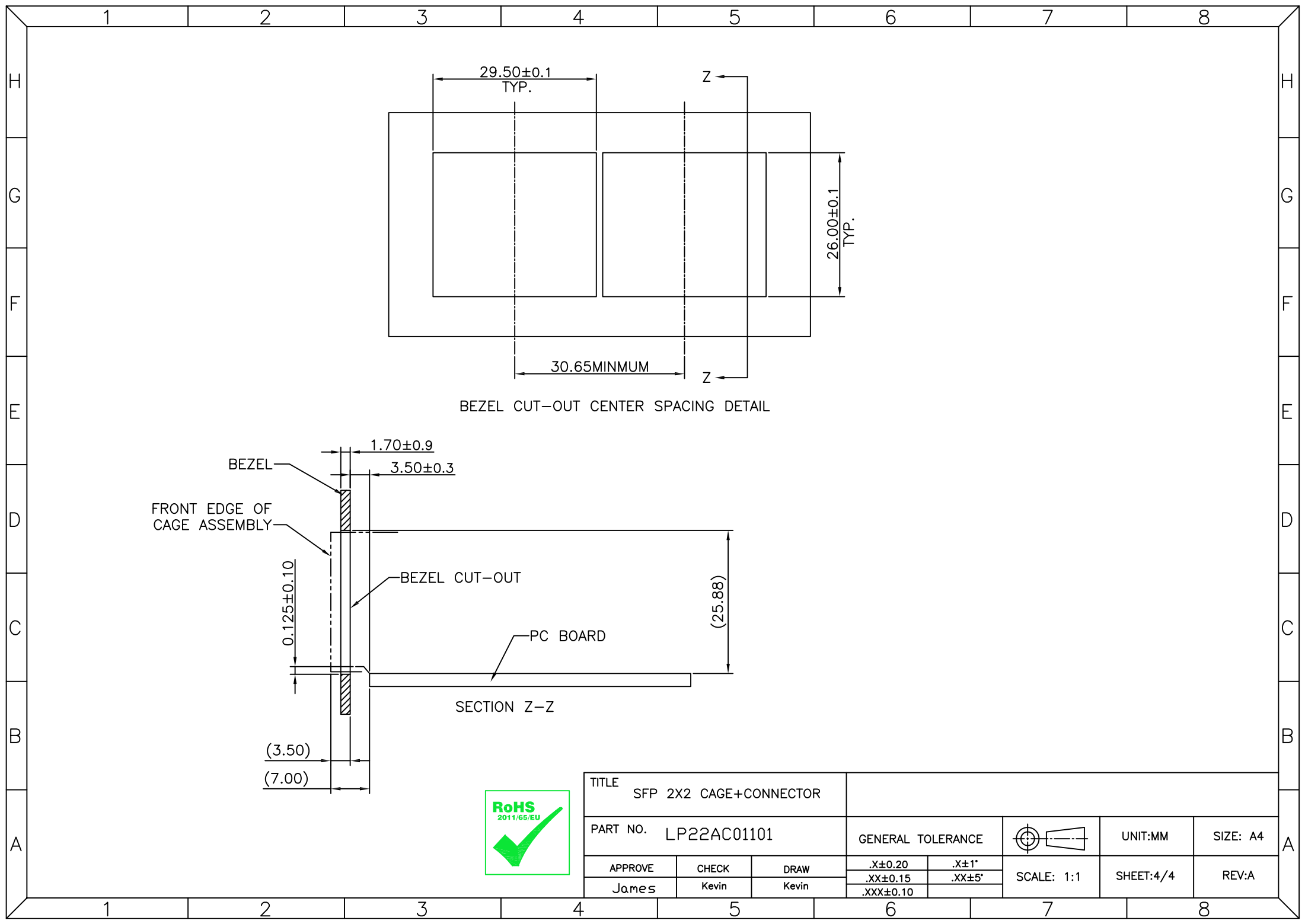

BEZEL CUT-OUT CENTER SPACING DETAIL

SECTION Z-Z



TITLE			SFP 2X2 CAGE+CONNECTOR				
PART NO.			LP22AC01101		GENERAL TOLERANCE	UNIT:MM	SIZE: A4
APPROVE	CHECK	DRAW	.X±0.20	.X±1'	SCALE: 1:1	SHEET:4/4	REV:A
James	Kevin	Kevin	.XX±0.15	.XX±5'			
			.XXX±0.10				