

REV	DESCRIPTION OF CHANGE	REVIEWED BY	ISSUE DATE
A	FIRST ISSUE	James	2021-08-01

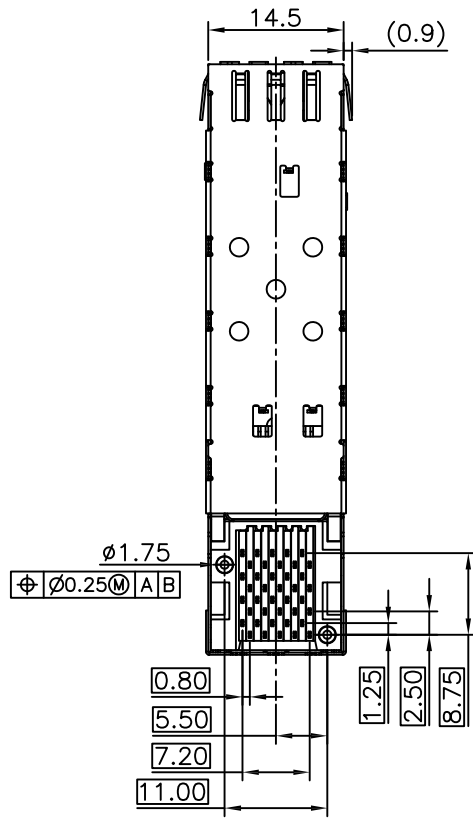

NOTES:

- MATERIAL:
- CAGE: COPPER ALLOY 30u" MIN NI-PLATED, THICKNESS 0.25 MM
- CONNECTOR:
- PLASTIC HOUSING: HIGH TEMPERATURE LCP, UL94 V-0.
- LIGHT PIPE: POLYCARBONATE; COLOR: CLEAR
- SPRING: STAINLESS STEEL, THICKNESS 0.20mm
- CONTACTS: PHOSPHOR BRONZE, THICKNESS 0.20mm
- PLATING: 15µ" MIN. GOLD ON MATING AREA, 150µ" MIN. MATE TIN ON SOLDER TAILS.
- PACKAGING: TRAY PACKAGING.
- TEMPERATURE RANGE: -40°C TO +85°C
- STORAGE TEMPERATURE: -55°C TO +105°C

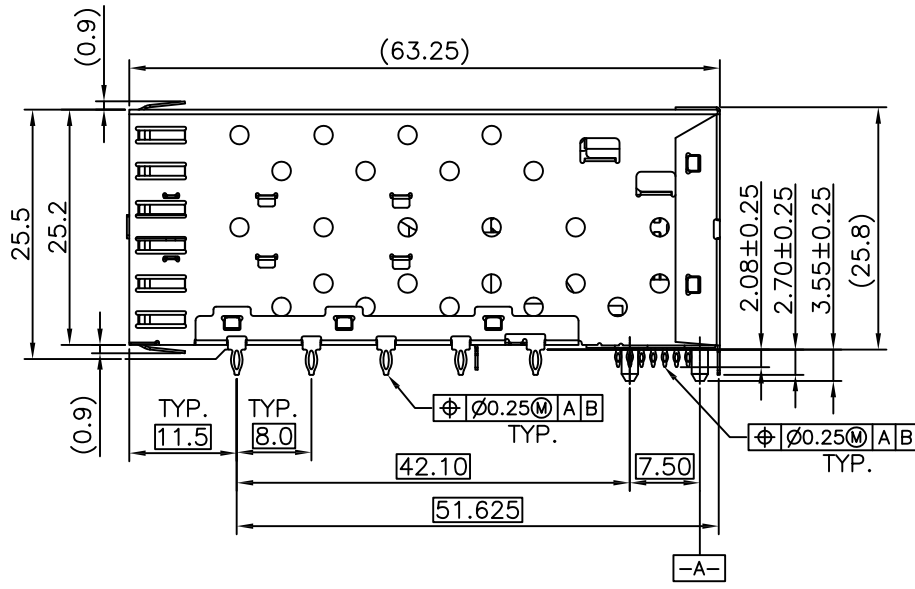
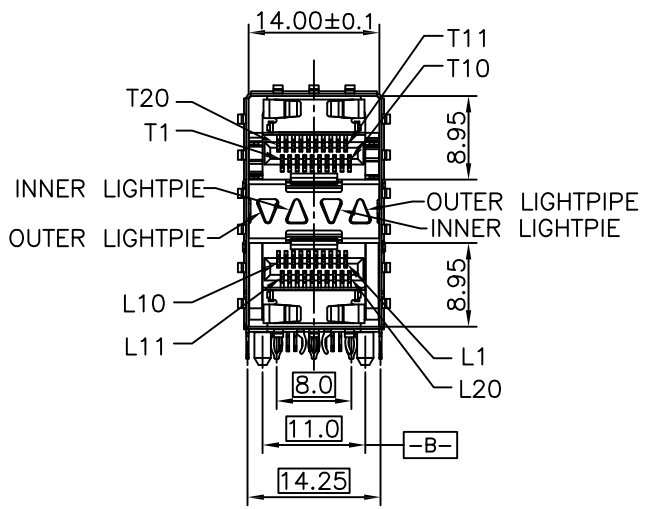

TITLE			LINK-PP INT'L TECHNOLOGY CO., LIMITED		
SFP 2X1 CAGE+CONNECTOR					
PART NO.			GENERAL TOLERANCE		UNIT:MM
LP21AC02101			.X±0.20 .X±1'		SIZE: A4
APPROVE	CHECK	DRAW	SCALE: 1:1		SHEET:1/3
James	Kevin	Kevin	.XX±0.15 .XX±5'		REV:A
			.XXX±0.10		

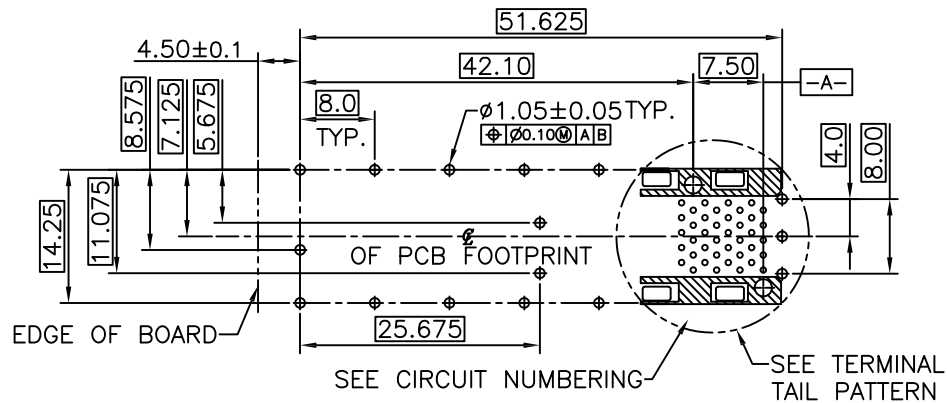

RECOMMENDED PCB LAYOUT – COMPONENT SIDE
 RECOMMENDED PCB THICKNESS : 2.36MM(.093 INCH)
 (MINIMUM PCB THICKNESS : 1.57)

THE ENTIRE AREA OF THE CONNECTOR FOOTPRINT
 TO BE CONSIDERED THE KEEP OUT AREA FOR COMPONENTS
 THIS AREA IS INDICATED BY THE DASHED LINE

L11	L10	T1	T20
L12	L9	T2	T19
L13	L8	T3	T18
L14	L7	T4	T17
L15	L6	T5	T16
L16	L5	T6	T15
L17	L4	T7	T14
L18	L3	T8	T13
L19	L2	T9	T12
L20	L1	T10	T11

CIRCUIT NUMBERING
 COMPONENT SIDE OF BOARD

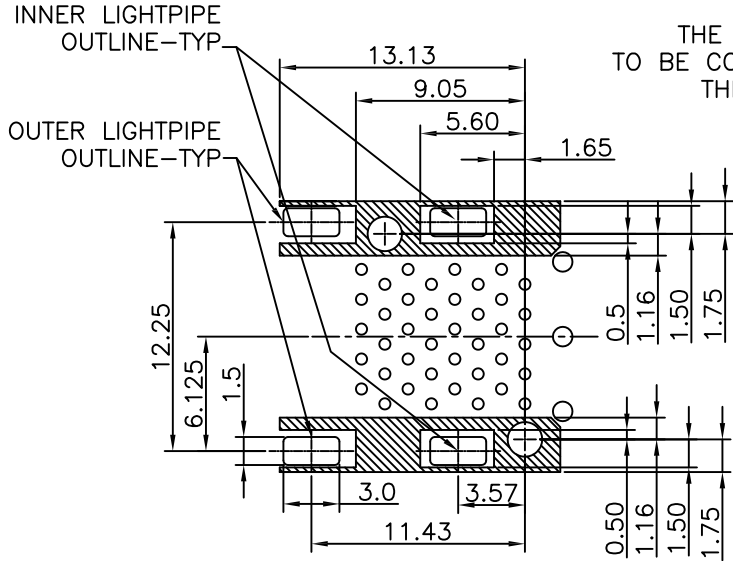

DETAIL-KEEPOUT ZONES

THE HATCHED AREA IN THIS VIEW INDICATES ZONES
 THAT ARE OCCUPIED BY THE PLASTIC HOUSING THAT
 SEATS AGAINST THE PCB AND BY THE VERTICAL METAL
 CAGE WALL THAT STOPS JUST SHORT OF THE PCB

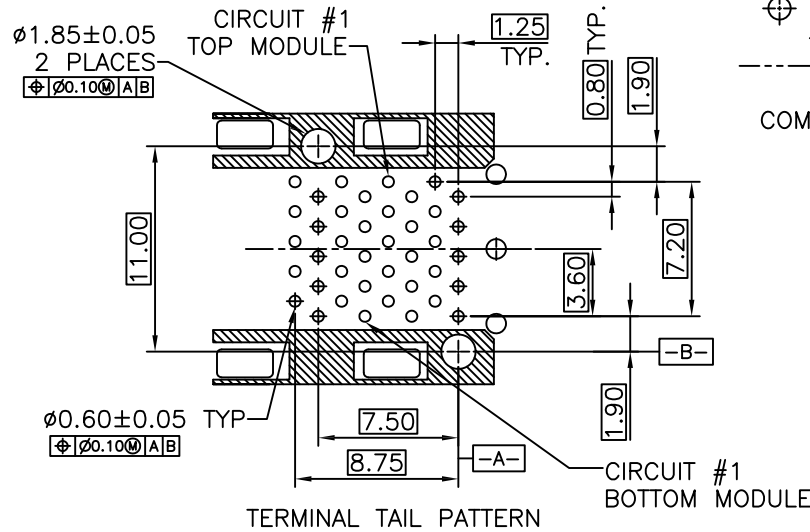

TERMINAL TAIL PATTERN

TITLE			LINK-PP INT'L TECHNOLOGY CO., LIMITED		
SFP 2X1 CAGE+CONNECTOR					
PART NO.			GENERAL TOLERANCE		UNIT:MM
LP21AC02101			.X±0.20 .X±1'		SIZE: A4
APPROVE	CHECK	DRAW	SCALE: 1:1		SHEET:2/3
James	Kevin	Kevin	.XX±0.15 .XX±5'		REV:A
			.XXX±0.10		

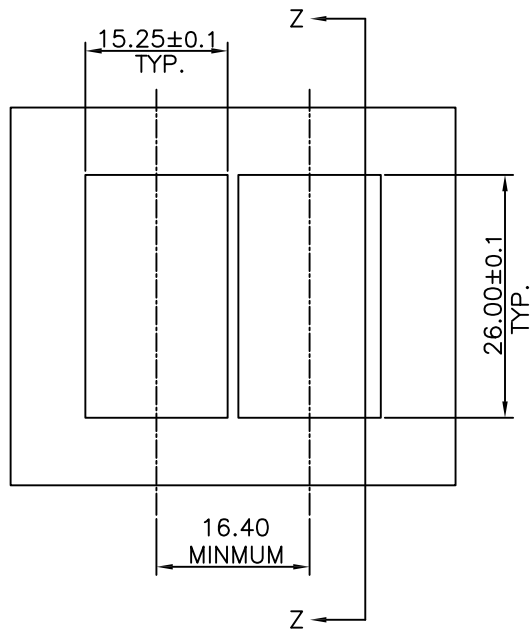

BEZEL CUT-OUT CENTER SPACING DETAIL

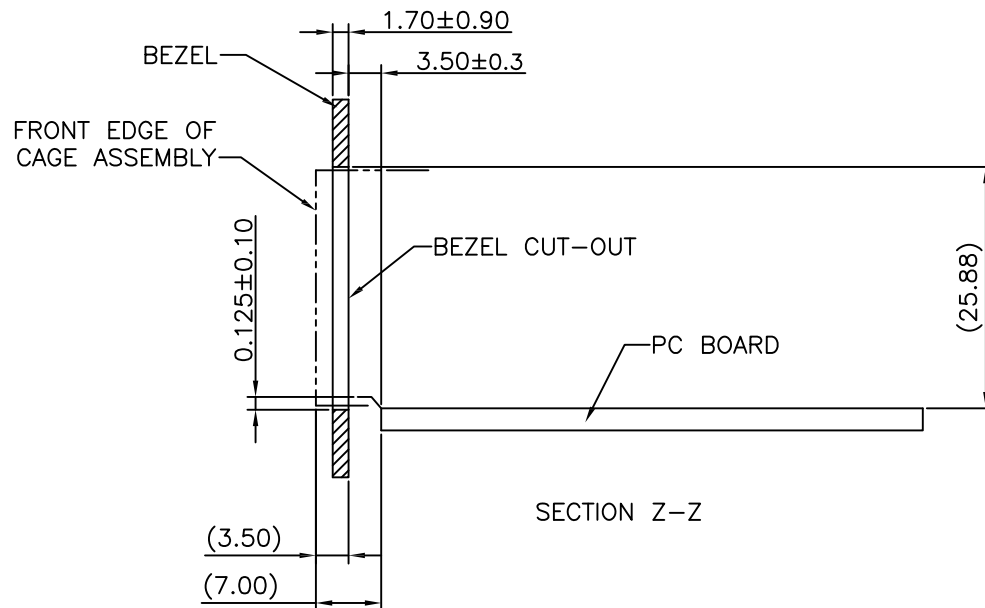

SECTION Z-Z



TITLE			LINK-PP INT'L TECHNOLOGY CO., LIMITED			
SFP 2X1 CAGE+CONNECTOR						
PART NO.			GENERAL TOLERANCE		UNIT:MM	SIZE: A4
LP21AC02101						
APPROVE	CHECK	DRAW	.X±0.20	.X±1'	SCALE: 1:1	SHEET:3/3
James	Kevin	Kevin	.XX±0.15	.XX±5'		
			.XXX±0.10			
					REV:A	